

# Panel Wiring Diagram Model EAS-S2 PT LAA

1.1  
1.2  
1.3  
1.4  
1.5  
1.6  
1.7  
1.8  
1.9  
1.10  
1.11  
1.12  
1.13  
1.14  
1.15  
1.16  
1.17  
1.18  
1.19  
1.20  
1.21  
1.22  
1.23  
1.24  
1.25

— = Factory Wire  
- - - = Field Wire

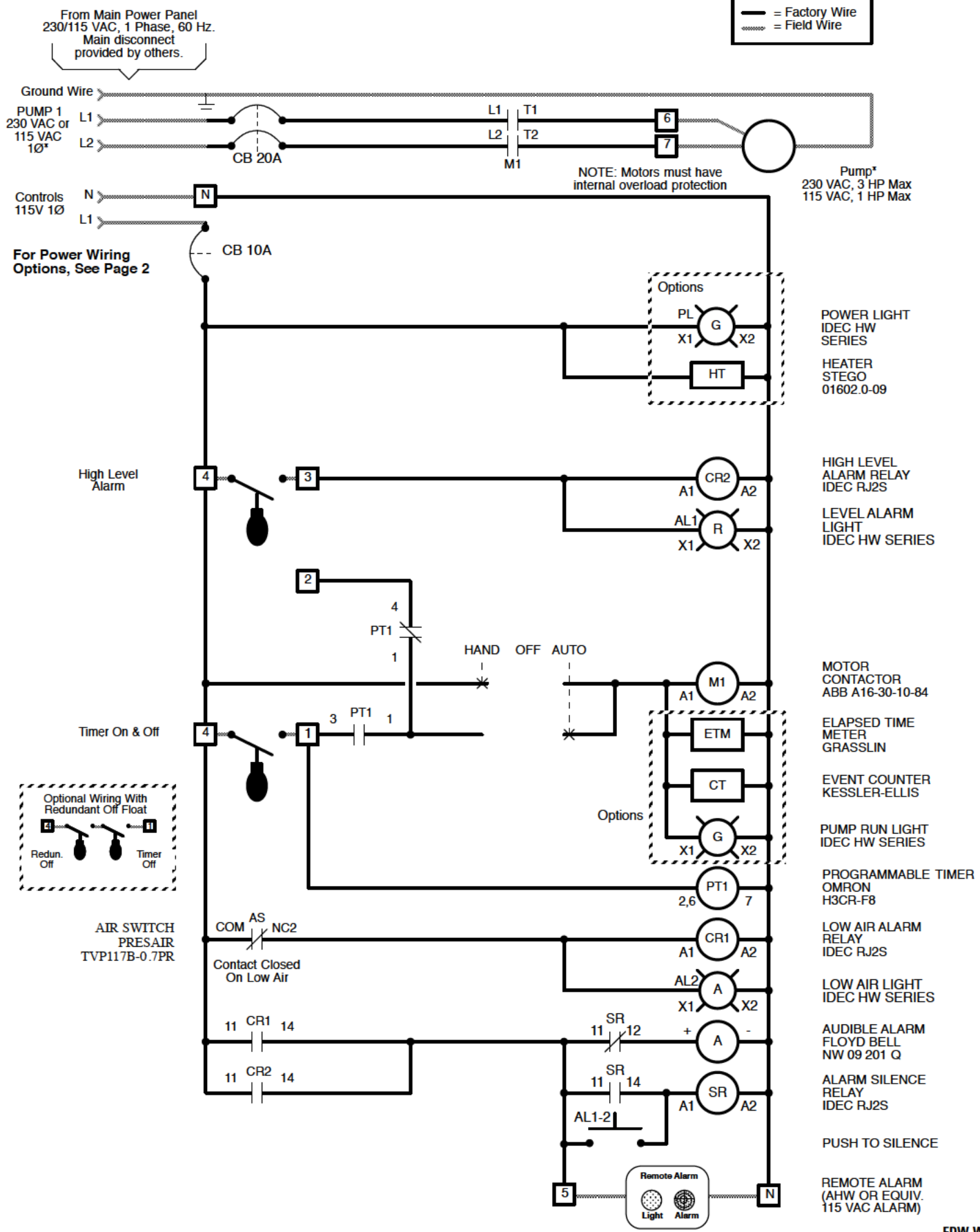

2.1  
2.2  
2.3  
2.4  
2.5  
2.6  
2.7  
2.8  
2.9  
2.10  
2.11  
2.12  
2.13  
2.14  
2.15  
2.16  
2.17  
2.18  
2.19  
2.20  
2.21  
2.22  
2.23  
2.24  
2.25  
2.26  
2.27  
2.28

### \*Power Wiring Options: 230 VAC Pump

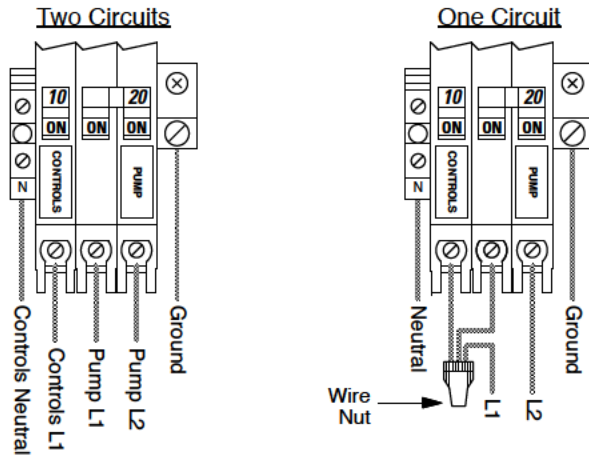

Factory default.  
Wire as shown.

Use a wire nut to connect the first pole of the pump circuit breaker together with the controls breaker and the incoming L1 power line.

### Simplex Operation

**High Level Alarm:** This float activates the alarm light and audible alarm when lifted. The audible alarm may be silenced by pressing the illuminated PUSH TO SILENCE button on the front of the control panel. The high level alarm light will remain on until the float is lowered.

**Timer On & Off:** This float turns off the programmable timer when lowered. When this float is lifted the timer will be restarted. Note: The timer will start with its off cycle.

**Programmable Timer:** The timer turns the pump on and off in a pre-set cycle. Note: The timer will start with its off cycle.

**Low Air Alarm:** The air monitoring switch activates the alarm light and audible alarm when low air pressure is detected. The audible alarm may be silenced by pressing the illuminated PUSH TO SILENCE button on the front of the control panel. The low air alarm light will remain on until the condition is corrected.

### \*Power Wiring Options: 115 VAC Pump

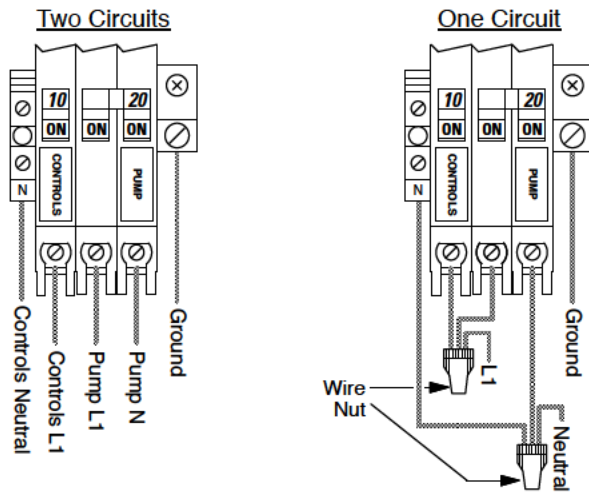

Factory default.  
Wire as shown.

Use one wire nut to connect the first pole of the pump circuit breaker together with the controls breaker and the incoming L1 power line. Use another wire nut to connect the second pole of the pump circuit breaker with the controls neutral and the incoming neutral line.

# H3CR-F8 Setting Instructions

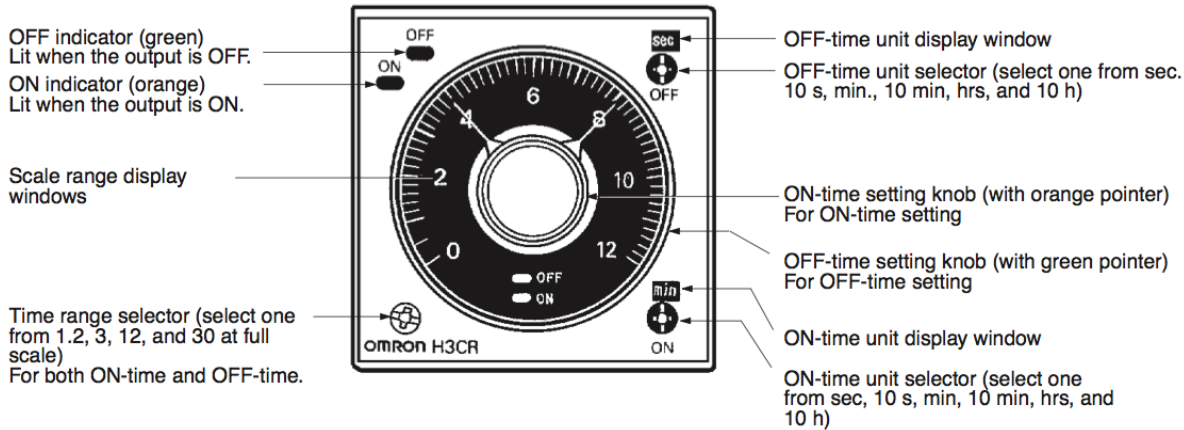

## Instructions:

1. Use a small screwdriver to set the range selection switch to the appropriate time range. Select from 0-1.2, 0-3, 0-12, or 0-30. The selected range must accommodate both the "on" and "off" time settings. If your desired time setting can be acquired in more than one time range, maximize accuracy by using the lowest time range possible. For example, a one-hour setting can be more accurately adjusted in the 0-1.2 time range than in the 0-3 time range.
2. Use a small screwdriver to set the off time selection switch to the required time unit for the "Off" time. Select from seconds (sec), seconds x 10 (10s), minutes (min), minutes x 10 (10m), hours (hrs) or hours x 10 (10h).
3. Set the off dial (large dial with the green pointer) to the off time required.
4. Use a small screwdriver to set the on time selection switch to the required time unit for the "On" time. Select from seconds (sec), seconds x 10 (10s), minutes (min), minutes x 10 (10m), hours (hrs) or hours x 10 (10h).
5. Set the on dial (small dial with the red pointer) to the on time required.
6. Record your timer settings in the space provided.

Timer Off:

Timer On:

## Default Setting:

The timer is factory set to 1 hour OFF, 40 seconds ON.

## Setting Example:

Set the timer to the above default setting.

1. Set the range selection switch to 0-1.2 range.
2. Set the off time selection switch to hours (hrs) range.
3. Set the off dial to 1.0 for 1 hour Off setting
4. Set the on time selection switch to minutes (min) range.
5. Set the on dial to approx. 0.67 for 40 seconds On setting.

EAS-S1PT-LAA SERIES CONTROL PANEL  
SEE SEPARATE WIRING DIAGRAM

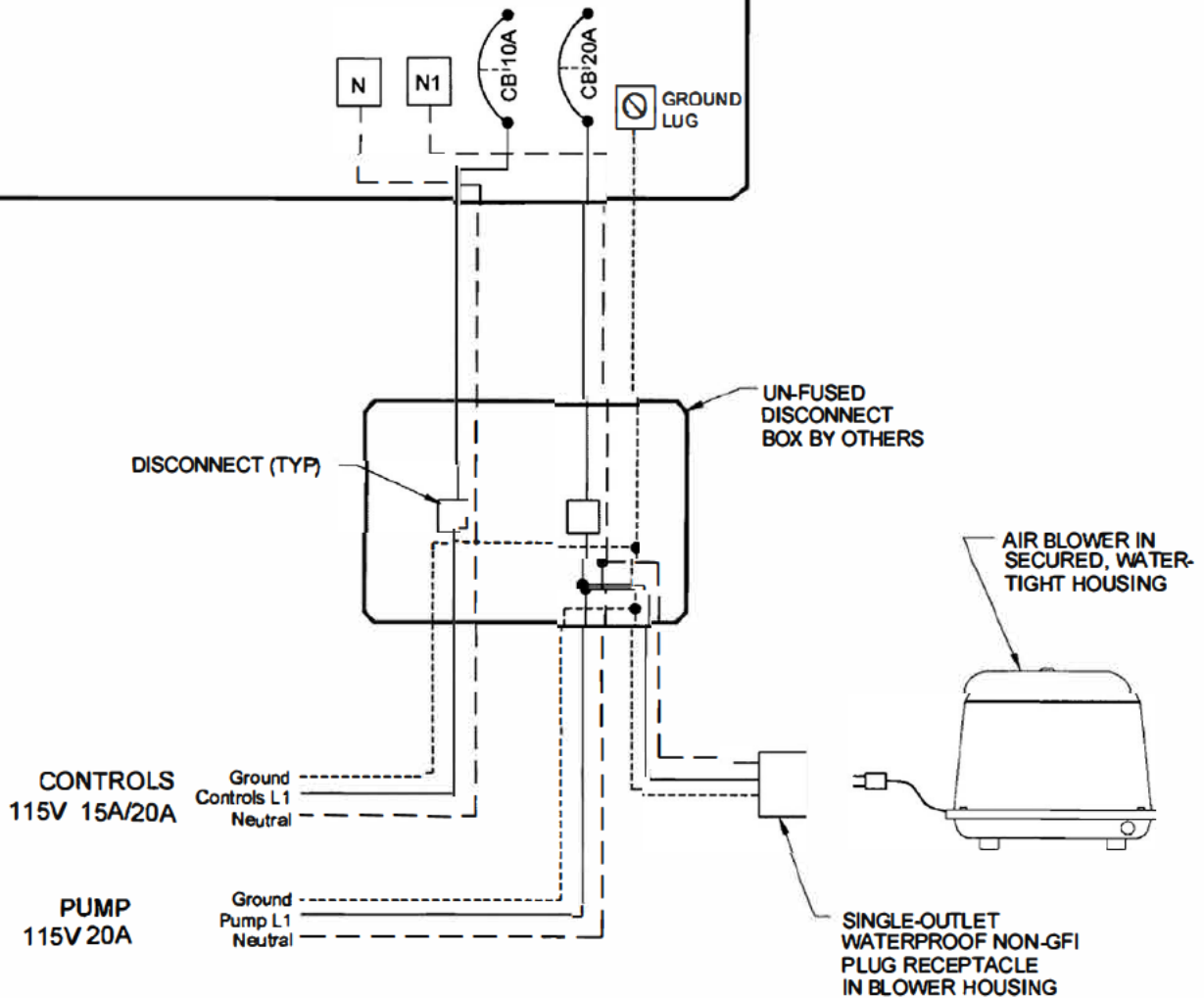

**NOTES:**

THESE FIGURES DEPICT A RECOMMENDED WIRING CONFIGURATION. OTHER POSSIBLE VARIATIONS INCLUDE:

3 CIRCUITS: ADD A SEPARATE CIRCUIT FOR THE AIR BLOWER.

USE OF BREAKERS: USES A SMALL BREAKER BOX. NOTE THAT NEC REQUIRES #10 AWG MIN. FEEDER SIZE IN THIS CASE.

230 VOLT PANEL: REQUIRES ENTIRELY SEPARATE 115V CIRCUIT FOR THE AIR BLOWER.

**OTHER NOTES:**

BLOWER RUNS CONTINUOUSLY, INDEPENDENT OF CONTROLS IN PANEL.

ALL WIRING TO BE WITHIN APPROVED CONDUIT.

SEE TREATMENT UNIT INSTALLATION MANUAL FOR CONNECTION OF LOW AIR LINE.



**AIR BLOWER & DISCONNECT WIRING DETAILS  
NUWATER ATU USING (2) 115V CIRCUITS**

NuWater  
Advanced Treatment Systems by Enviro-Flo  
Washington Contact: [www.NuWaterSeptic.com](http://www.NuWaterSeptic.com)

EIN-CP-MISC-49  
rev 2.0 3/20/19