

## INSTRUCTION MANUAL

### MAINTENANCE TECHNICAL MANUAL

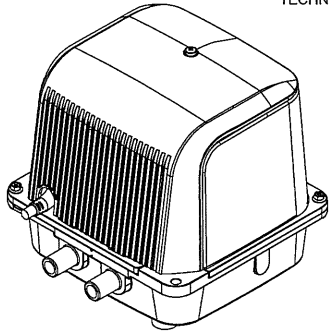

MODELS  
DUO-50  
DUO-60  
DUO-80

This is a hazard alert symbol: ⚠ When you see this symbol, be aware of possible personal injury or property damages. The hazard is explained in the text following symbol. Read information carefully before proceeding.

The following explanations are the three different types of hazards:

- ⚠ **DANGER:** Indicates a hazardous situation which, if not avoided, will result in death or serious injury.
- ⚠ **WARNING:** Indicates a hazardous situation which, if not avoided, could result in death or serious injury.
- ⚠ **CAUTION:** Indicates a hazardous situation which, if not avoided, could result in minor or moderate injury.

KA0809030-01 1705

1

## OPERATION

- ⚠ **WARNING:** Lower housing and pump surface can be very hot during operation. Do not touch pump surfaces until the unit cools down.
- ⚠ **CAUTION:** Carefully examine the air pump before plugging in. It should not be plugged in if there is any parts that would potentially be wet.
- ⚠ **CAUTION:** Do not operate if the cord or plug is damaged, or if the pump is malfunctioning, dropped, or damaged in anyway.
- ⚠ **CAUTION:** Make sure that the pump is securely mounted prior to operation.

When alternating current is applied to electromagnet as in the figures, the actuating rod moves first in the arrow direction shown in Fig. 2A and then in the arrow direction shown in Fig. 2B, by the magnetic attraction and repellent forces exerted between the electromagnet and the permanent magnets attached to the rod.

The rod vibrates at the power supply(60Hz/50Hz)frequency and changes the volume of the space enclosed between the head(casing) and the diaphragm. Thus, air intake, compression, and exhaust, can be performed as the rod vibrates.

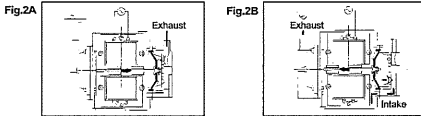

## MAINTENANCE

- ⚠ **WARNING:** Be sure to unplug the pump unit before installing or maintenance. Failure to do so could result in electrical shock, personal injury or death. If the thermal protection switch is tripped, the electromagnetic part will automatically restart after it cools down.
- ⚠ **CAUTION:** The filters must be periodically cleaned or replaced. Clogged filter can cause over-heating or pump failure.

Any pump maintenance other than that recommended in the instruction manual must be done by an Authorized Service Facility. Filter inspection every three months is recommended. When inspecting filter, also clean inlet port area of filter and housing. Filter can be washed with soap and water. Make sure that filter is dried before reattaching. In case the pump makes an abnormal noise or the outlet air is distinctly decreased, immediately unplug the pump unit.

For repair replacement parts, please contact to the factory or send unit to Authorized Service Facility.

5

## GENERAL INFORMATION

- ⚠ **DANGER:** Do not pump flammable or explosive gases or operate the unit in an atmosphere containing them.
- ⚠ **CAUTION:** The pump is designed for air only. Do not allow corrosive gases or particulate material to enter the pump. Water vapor, oil-based contaminants, or other liquids must be filtered out.
- ⚠ **CAUTION:** Ambient temperature should be exceed 40°C(104°F). For operation at higher temperatures, consult the factory.
- ⚠ **CAUTION:** Close supervision is necessary when any appliance is used by or near children.

This pump's function is to pump air and under no circumstances should it be used to pump any other gases. The pump must not be used for the pumping of fluids, particles, solids or any substance mixed with air, particularly combustible substances likely to cause explosions.

Never lubricate this oil-less pump, the moving parts consist of an actuating rod supported by two special synthetic rubber diaphragms which vibrate laterally, permitting long-term continuous operation. Operation is based upon the principle of electromagnetic vibration which eliminates the need for sliding parts, thereby minimizing power consumption and offering high efficiency.

## INSTALLATION

- ⚠ **WARNING:** To avoid risk of electrocution do not use this product in an area where it could be submerged in water or other liquids. The pump need to be stored in a dry location and it is not intended for outdoor use in Canada.
- ⚠ **CAUTION:** Do not block the flow of cooling air around the pump in any way. The life of pump may be reduced or malfunction could occur, if hazard is ignored.

2

Cleaning the filter (Refer to Fig.1)

- Remove screw (refer to fig.1-①). Detach filter cover from upper housing (refer to fig.1-②).
- Replace with a new filter or clean up the filter. Dust off filter to remove dirt and dust in case it is soiled heavily (refer to fig.1-③).
- (Filter can be washed with soap and water. Make sure that filter is dried before reattaching.)
- Remove the dust at upper housing (refer to fig.1-④).
- Put filter and make sure that all 8 projections stay in every holes of filter gasket (refer to fig.1-⑤).
- Attach filter cover. Insert bosses on the bottom of filter cover into flutes on upper housing (refer to fig.1-⑥).

Fig.1

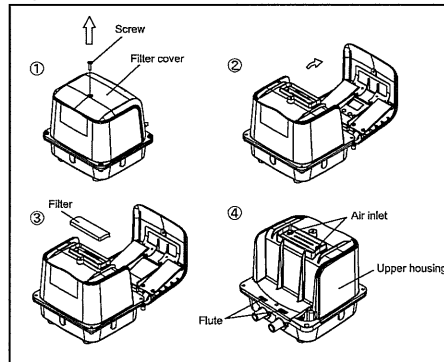

6

## SERVICING OF DOUBLE-INSULATED PRODUCT

Two insulation constructions are provided in the double-insulated product. As the ground wire is not necessary for double-insulated product, it is not attached to the product.

As it requires extreme care and knowledge of the system to service of a double-insulated product, it should be done only by qualified serviceman. Genuine replacement parts for the double-insulated product must be used for your safety.

A double-insulated product is marked with the words "DOUBLE INSULATION" or "DOUBLE INSULATED".



The symbol may also be marked on the product.

## FOR PERMANENTLY CONNECTED PRODUCT

This product should be connected to a grounded, metallic, permanent wiring system, or an equipment-grounding terminal or lead on the product (Refer to wiring diagram below).

WIRING  
120V AC Wiring Diagram

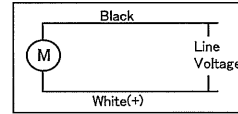

3

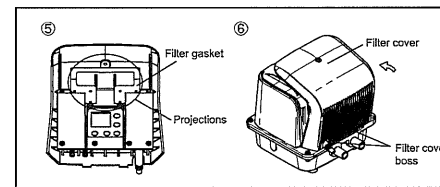

Replacing Pump (Chamber) Assembly

- [1] Replacing built-in block (Refer to Fig.2)
- Remove all 5 screws and remove upper housing (refer to fig.2-①).
- If it is stuck, insert screwdriver between upper housing and lower housing to pry apart.
- Remove sound absorber (refer to fig.2-②).
- Pull connector out holding ↓ part (refer to fig.2-③).
- Remove a screw of cord clamp.
- Remove 4 cushion rubbers. Remove built-in part (refer to fig.2-④).

Fig.2

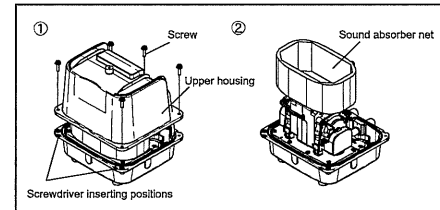

7

## EXTENSION CORDS

Use only 2-wire extension cord that has a 2-blade(Type A) no-grounding plug, and a 2-slot receptacle(Type A). Make sure your extension cord is in good condition. When using an extension cord, be sure to use one heavy enough to carry the current that your product will draw. A cord less than 100 feet, No.16 AWG extension cord should be used. An undersized cord will cause a drop in line voltage resulting in loss of power and overheating. For outdoor use, use an extension cord that is approved for outdoor use, marked W-or W-A.

## MOUNTING

- ⚠ **CAUTION:** When the operation, make sure that the pump is put higher than the water surface. Otherwise the liquid may flow backward into the pump is unplugged.

The pump should be in an upright, level position and remain on a stable, rigid operating surface for proper operation.

## PLUMBING

Improper connection will cause air leakage.

Connect the PVC (plastic) pipe with an L-shaped rubber hose to the exhaust port for pump. Make sure that the hose is connected properly with a hose tightening clip (Refer to Fig.1).

Fig.1

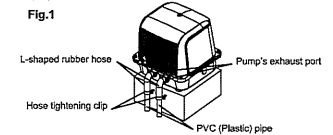

## STORAGE

Store indoors out of the weather in a dry area. Make certain the electrical cord in placed so there will be no chance of damage.

- ⚠ **CAUTION:** To avoid risk of electrocution or damage to the pump, do not store the unit where it could be flooded when it rains or snows. Store indoors for use in Canada. Make sure that the compressor and power cord is not damage prior to putting compressor back.

4

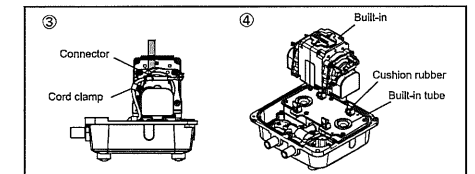

[2] Replacing chamber block (Refer to Fig.3)

- Remove built-in cover. Pick ↑ part up to remove the cover (refer to fig.3-①).
- Insert gap jig for XP (that is attached to DUO repair kit) deeply to one side (refer to fig.3-②).
- Remove one side of casing block. Loosen casing mounting screws and remove casing as shown in fig.3-③.

Fig.3

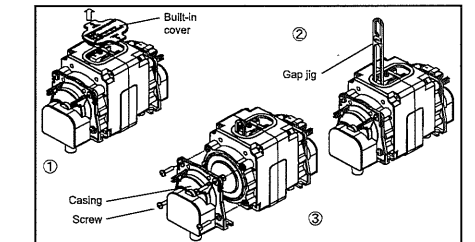

[3] Replacing Diaphragm block (Refer to Fig.4)

- Remove locknut and washer (refer to fig.4-①).
- Remove diaphragm ring and diaphragm (refer to fig.4-②).
- In case it is not easy to remove, pull with long nose pliers.
- Attach one side of diaphragm. As shown in fig.4-③, put shadowed area together. Insert new diaphragm into groove on frame.

8

- Attach diaphragm ring back together (refer to fig.4-④). Use new diaphragm ring (attached to diaphragm parts).
- Attach washer and tighten locknut as shown in fig.4-①.
- Make sure that the center plate is at the center of a diaphragm (refer to fig.4-⑤).

Fig.4

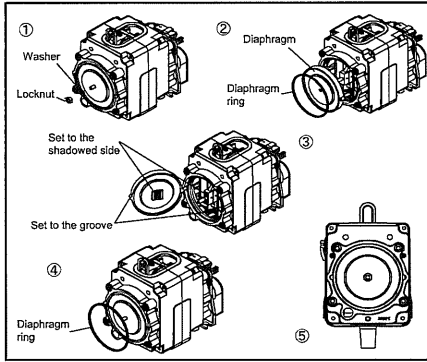

- Attach casing block. Tighten 4 casing mounting screws as shown in the fig.3-③.
- Exchange opposite diaphragm repeating the same steps.

9

- Attach connector to motor with  $\Delta$  part upside (refer to fig.8-⑤ and fig.8-⑥). If it is attached reversely, it can not work.
- Do NOT catch harness between motor and lower housing. Attach motor rail block and tighten 2 tapping screws using Philips head screwdriver (refer to fig.8-⑦ and fig.8-⑧).

Fig.8

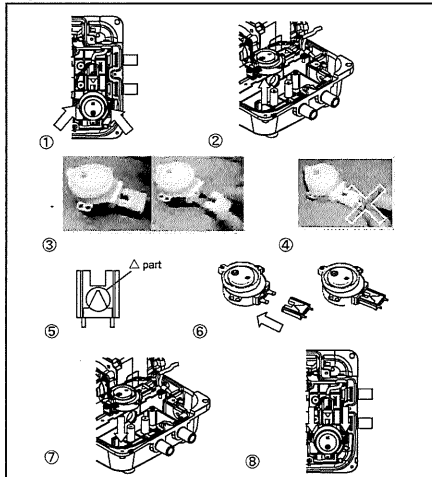

13

- [4] Replacing Safety Switch (Refer to Fig.5)
- Automatic stop switch may work. In this case, please follow steps below for return operation.

Fig.5

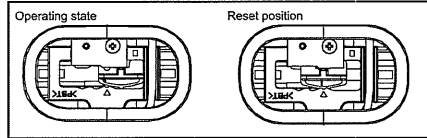

- [5] Reinstalling Built-in block (Refer to Fig.6)

- Reattach built-in cover parallel to frame (refer to fig.6-①).
- Reattach 4 cushion rubbers to built-in part, connect power cord and terminal for built-in part. Reattach lead wire to casing as shown in fig.6-②.
- Tighten a screw of cord clamp.

Fig.6

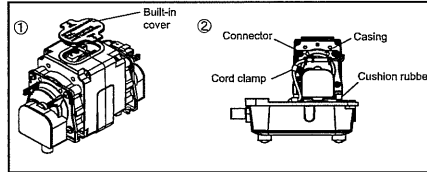

10

- [9] Replacing Sensor PCB (Refer to Fig.9)

Note: Holding mounted part of sensor or resistor can cause short circuit due to static electricity and be damaged.

- Make sure holding and faces. Do NOT put mounted part on a desk or floor (refer to fig.9-① and fig.9-②). Do NOT pull harness wire out holding it strongly. It may cause breaking wire (refer to fig.9-① and fig.9-②).
- Remove a screw using Philips head screwdriver (refer to fig.9-③).
- Detach sensor PCB holding end faces (refer to fig.9-④).
- Pull connector on the back side of sensor PCB by hand (refer to fig.9-⑤).
- Insert connector to sensor PCB (refer to fig.9-⑥).
- Attach sensor PCB and tighten M3 SUS blinding head screw (refer to fig.9-⑦ and fig.9-⑧).
- If it is attached reversely, it can not work (refer to fig.9-⑦).

Fig.9

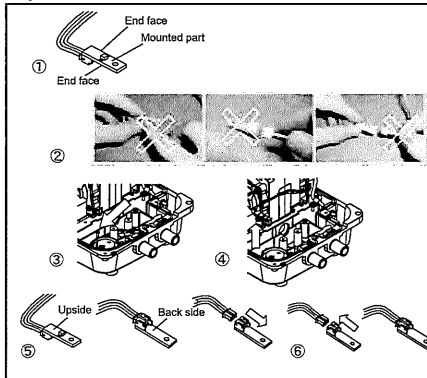

14

- [6] Reinstalling Upper housing (Refer to Fig.2)
- Reattach sound absorber (refer to fig.2-②), make sure housing gasket is set properly before attaching upper housing.
- Tighten 5 screws evenly.

- [7] Replacing Valve pipe block (Refer to Fig.7)

- Remove 2 tapping screws using Philips head screwdriver (refer to fig.7-①).
- As shown in fig.7-②, remove valve pipe block from lower housing.
- In case that tank tube shapes reversely, push tank tube toward the arrow direction (refer to fig.7-③ and fig.7-④).
- Insert valve pipe block deeply into tank tube of lower housing (refer to fig.7-⑤).
- Put roller of valve pipe block on rail while moving and adjusting cylinder by fingers (refer to fig.7-⑥).
- Make sure that the roller is on the groove of the rail (refer to fig.7-⑦).
- Attach valve pipe block and tighten 2 tapping screws using Philips head screwdriver.

Fig.7

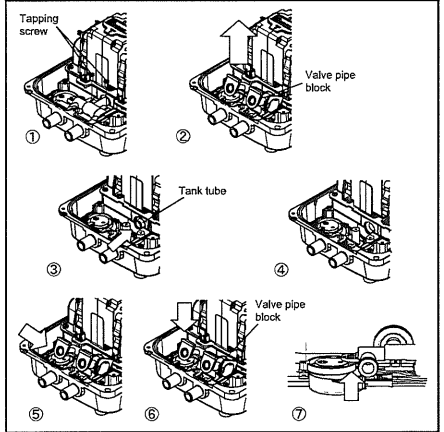

- [8] Replacing Motor rail block (Refer to Fig.8)

- Remove 2 tapping screws using Philips head screwdriver (refer to fig.8-①).
- Detach motor rail block holding motor part (refer to fig.8-②).
- Pull connector out from motor by hand (refer to fig.8-③).
- Do NOT pull harness wire by hand (refer to fig.8-④). It may cause breaking wire.

12

## TROUBLE SHOOTING

Symptom	Possible cause	Point to check up	Remedy
Pump fails to work	Electrical connection	Plug and outlet	Plug securely into outlet
	Wire cut inside the cord	Check with tester	Change power cord, electromagnet or lead wire
	Safety switch activated	Check ● Safety switch ● Chamber Block	Exchange diaphragm or safety switch
Pump works but makes irregular noise	Diaphragm damaged		Exchange casing or diaphragm mounting block
	Faulty valve	Remove upper, lower housing and trace the source of cause	
	Faulty chamber block		
	Faulty filter	Filter clogged	Clean up filter
Pump works but air comes from reservoir	Valve chamber cover out of place	Faulty tube	Repair or replace with new one
	Faulty piping connection	Rubber hose out of place, broken	Connect properly or replace with new one
	Pump runs normally	Air piping clogged	Clean properly

For repair or replacement parts, please contact to the factory or send unit to Authorised Service Facility.

16

## OPERATION OF COMPRESSOR TIMER MODULE

## GENERAL INFORMATION

- ⚠ DANGER: Do not attempt to disassemble the timer module. If the unit is connected to electricity, disassembling the timer module can result in a risk of electric shock.
- ⚠ DANGER: Service of the timer module should only be done by qualified serviceman.
- ⚠ DANGER: If the timer module is cracked or damaged, unplug immediately and contact to qualified serviceman.
- ⚠ CAUTION: Do not carry the pump unit holding timer module or power cord as it could damage the timer module.
- ⚠ CAUTION: Do not push button of timer. Timer setting changes and might not operate normally.

11

15